

# RollerCash 405/805

RollerCash increases security and improves cashier efficiency.

## INTRODUCTION

RollerCash is a combined cash handling system and security device that allows instant deposits and time-controlled withdrawals. Cashiers can increase or decrease their till drawer cash holding without leaving their workstation to access the main safe, decreasing the exposure of cash at any one time and allowing business to be conducted without disruption.

In open plan offices, each RollerCash position is self-sufficient with no need for back up from a main safe nor the assistance of a head cashier and no requirement for bulk cash to be carried across the public banking hall during branch opening hours.

RollerCash is available in a number of physical and functional formats all of which can be set to single user or up to six users simultaneously.

## DESCRIPTION

The heart of RollerCash is a rotating drum with 20 segments each with capacity for up to 200 banknotes available through an open-fronted cash dispenser.

The software controlled motor rotates the drum to expose only one segment at a time. Between segment openings and in the OFF state, a shutter closes the segment access aperture.

All models have a Total Withdrawal function giving access to each segment in turn without time-bar for balancing or emptying the unit when the branch is closed and the external perimeter is secured.

## FORMATS

RollerCash is available in two hardware formats:

**405** for cash used during trading hours with staff present but transferred to vault or safe overnight.

**805** BS EN 1143-1 Class I safe rated, normally insurable for 24 Hour cash holding of up to £10,000 but can be increased to £20,000 with other security measures.

**Options** include mini-safes and till drawers or flip top tills with coin and note denomination separators.

RollerCash is available in three functional formats:

**On-board Keypad, 2 Function Keys with 2\*20 Character LCD Display** for stand-alone use for deposits/withdrawals by Denomination or by Value per segment.



**Remote Keypad, 8 Function Keys with 4\*20 Character LCD Display** for stand-alone use for deposits/withdrawals by Denomination or by Value per segment plus greater display capacity and functionality.



**Windows™ interface** via an RS232 communications port for connection to an industry standard PC.

The communications and command protocols are available for clients to develop their own on-line interfaces. The contents (currency/denomination and value) of each segment is entered and deposits/withdrawals are commanded via the keyboard/mouse.

A Windows™ application programme is available for stand-alone operation of RollerCash for Sterling only or Foreign Exchange cash management with a full audit trail produced in Microsoft Access database format.



SAFE TELL DATA

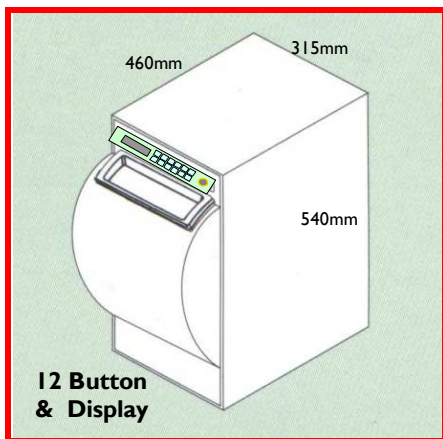

Standard 405 Casing or Safe rated 805 Casing
Motorised Drum Rotation 20 Segments 200 Notes per Segment
<b>Control Options</b>
On-board 2 Fn Keys & Display Remote 8 Fn Keys & Display RS232 Comms I/F

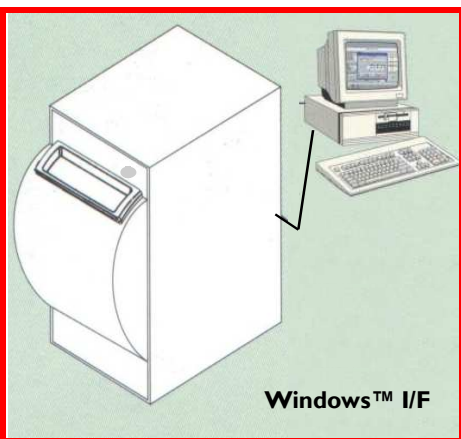

## **APPLICATIONS**

RollerCash is used in businesses which have a two-way flow of cash: e.g. Banks, Building Societies, Post Offices, Betting and Lottery outlets, Foreign Exchange and Pawnbrokers. More than 60,000 units have been installed across Europe since the product was launched in 1991. RollerCash is ideal for busy transaction areas with a high risk of robbery attempts and with a need to increase branch efficiency.

## **CASING OPTIONS**

RollerCash can be factory fitted with a Till Drawer and/or Side Cupboard.

Single or Double Plinths can be supplied to raise the operating height of the unit, to accommodate false floor voids and as secure tie-down points.

The 805 model is equipped with a seismic detector mounting plate.

## **TECHNICAL DETAILS**

**For guidance only. Refer to Safetell for specific details.**

Both RollerCash models have the same external dimensions:

W = 315mm H = 540mm D = 460mm

The optional till drawer is 140mm high above the unit. The optional side cupboard is 175mm wide.

Where fitted, the side cupboard can be fitted with a separately time-barred mini-safe (internal dimensions 155W \* 400H \* 250D mm).

Steel plinths lift the RollerCash unit to meet the ergonomic requirements of standing or seated cashiers. Plinths for the 805 model provide the BS EN 1143-1 specified tie-down resistance.

RollerCash weighs between 70kg and 130kg depending on the model and casing.

Each RollerCash requires a 230V, ac, 1 Phase, 50 Hz mains power supply fused at 5 Amps. RollerCash has a battery back-up that will provide autonomous operation for approximately 100 deposit/withdrawal cycles.

## **MAINTENANCE**

RollerCash benefits from occasional planned maintenance for battery changes, mechanical checks and cleaning of moving parts.

Safetell offers various extended warranty and other contract options to provide service support, with guaranteed response times if required, and has an established, nationwide service network for ad-hoc repairs in the event of a malfunction.

## **OTHER PRODUCTS/SERVICES**

Safetell also supplies other forms of Cash Handling equipment – RollerCash TRIO, BiDi Safe (Standard, Magnum and Magnum Plus) and a range of Bullet and Attack Resistant screens - Eclipse, CounterShield, Eye2Eye, & FlexiGlaze.

## **SECURITY**

To prevent unauthorised access to the contents, RollerCash has a pre-set time-bar for access to each segment. The time-bar settings are determined by the end-user, embedded in the software and set in the factory before delivery.

Time-bar settings may be absolute or relative to the coded value or denomination or to the time elapsed since the last withdrawal. Branch staff have no ability to change the time settings.

The steel casing has internal fixing holes for floor mounting.

The unit is equipped with a Dallas “I-button” receiver to lock and disable the RollerCash.

RollerCash 405 is designed as a secure storage unit for cash when premises are attended.

RollerCash 805 is certified to BS EN 1143-1 Class I for overnight cash holding within the unit.

## **INSTALLATION**

RollerCash is normally bolted directly to the floor at a counter position for additional security.

Units with drawer and/or side cupboard can be used as an alternative to pedestal units.

## **STAFF SAFETY**

Access to the motorised drum while it is rotating is impeded by an automatic, fail safe shutter.

RollerCash is a deterrent to crime and, as such, can help reduce the trauma associated with the effects of armed robbery.

## **TRAINING**

An Operator’s Quick Reference Guide and a fully detailed Manual are provided with each unit.

On-site staff training in the operation of RollerCash can be provided.